

# Splashwall<sup>®</sup>

Shower and Wall Panelling

## **INSTALLATION GUIDE**

## Contents

1.0	Inspection	3
2.0	Storage	3
3.0	Handling	3
4.0	Planning & Preparation	3
5.0	Panels	5
6.0	Accessories	5
7.0	Tools & Fixings	6
8.0	Fitting Tips	7
9.0	Two Sided Shower Installation	8
10.0	Three Sided Shower Installation	9
11.0	Full Room Installation	10
12.0	Bottom & Skirting Details	11
13.0	Window, Door & Finishing Details	11
14.0	Cleaning	11

## 1.0 Inspection

Panels must be thoroughly inspected upon receipt for damage or visible defects. The panels are supplied with a protective clear film to the decorative face, this should be peeled back to check for damage or discrepancies in colour where necessary then replaced to provide protection during commencing installation.

***Do not install panels that you find to be defective.***

Once the panels or profiles have been cut or installed we regard this as an acceptance of their quality and suitability for purpose and therefore we cannot accept any subsequent claims for faults or damage.

## 2.0 Storage

Panels should always be stored flat to avoid bowing. Prior to installation the panels, adhesives and sealants should be conditioned for a minimum of 48-72 hours in the area in which they are to be installed or an environment of similar temperature or humidity. Drastic changes in conditions can cause the panels to bow and twist irreversibly.

- Panels should never be stored outside.
- Panel Adhesive should be stored in cool dry conditions between 5 - 25°C.

## 3.0 Handling

Laminate panels have extremely sharp edges and we advise that suitable gloves be worn for protection when handling and installing them.

## 4.0 Planning & Preparation

Before you undertake any type of installation it is always wise to carry out a degree of planning that might save you a lot of time and grief later on. Below are some points that may help.

### 4.1 Walls

Splashwall can be fitted to almost any surface including plaster board, existing tiling, concrete, chipboard & plywood sheathing and plaster providing the surface it is sound, plumb and level. Some surfaces do require pre-treatment before installation, tiles should be de-greased and fresh plaster should be sealed with a proprietary PVA sealer.

If your walls aren't plumb and level then this can be achieved by using softwood timber framing [min. ex 50 x 25mm].

The timber framing should be fixed horizontally, giving support to the panels at the top and bottom and at a minimum of 500mm centres between. The frame should be packed out where required using spacers or packing wedges to achieve a plumb and level surface.

Additional framing should also be provided where heavier items are to be fitted through the panels.

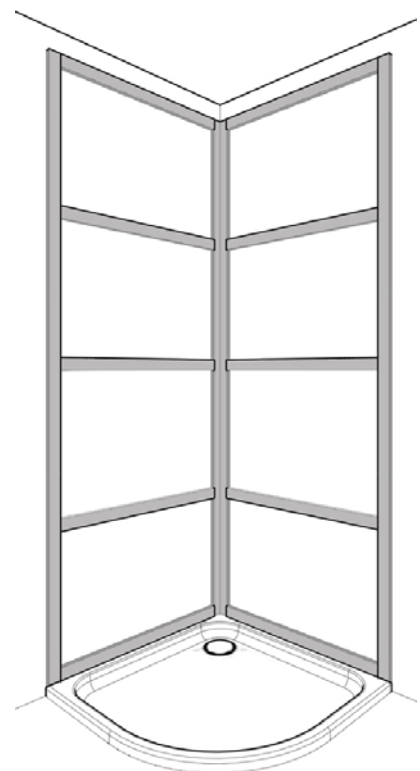

## 4.2 Services

Necessary pipe work should be fitted and short tails left where they are to pass through panels.

Electrical cabling should be in place and routed to avoid subsequent fixing points.

Shower trays and baths should be fitted in position, these should also be sealed in accordance with the manufacturers recommendations.

## 5.0 Panels

All panels are 11mm thick overall and are supplied with a clear plastic protective film.

	<b>Width/Height</b>	<b>Edge Detail</b>	<b>Weight (approx.)</b>
Shower Panel	1200mm x 2400mm	Square	24Kg
Shower Panel	900mm x 2400mm	Square	18Kg
Wall Panel	*1185mm x 2400mm	Tongue & Grooved	24Kg

\*width of decorative face

## 6.0 Accessories

Splashwall profiles come in \*2420mm lengths and are available in Satin Anodised Aluminium (SAA), white, polished silver and black finishes (unless otherwise indicated). It is recommended that Splashwall Silicone Sealant and Adhesive is used for all installations.

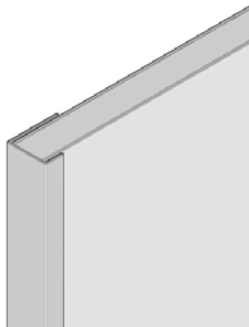

**End Cap**

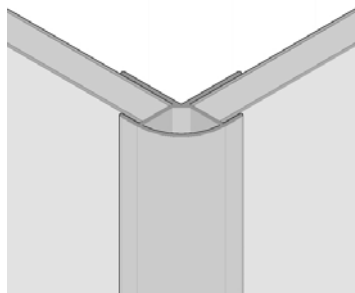

**External Corner**



**Internal Corner**

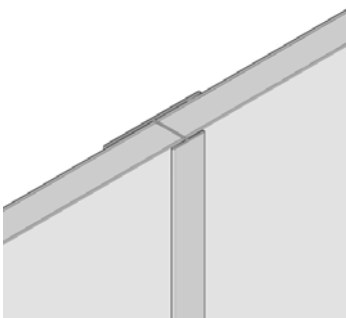

**H Joint**

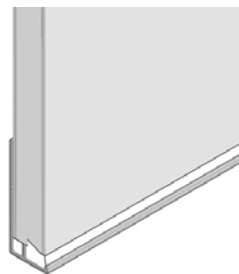

**Bottom Profile (SAA only)**

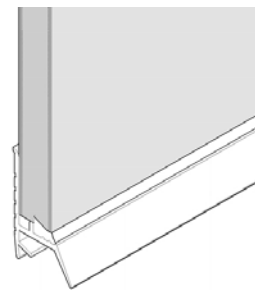

**Splashseal (White only)**  
\*1850mm long

## 6.1 Splashseal Kit

The Splashseal kit was introduced to provide all the components required to install a bottom seal to almost any single shower or bath installation.

The kit consists of the following components –

- 2 x white plastic seals 1850mm long
- 2 x 330ml tubes of Sealux-N sealant
- 1 x Mitre box
- 2 x End caps (for the end of the seal)
- 1 x Application Spatula
- 3 x Alcohol Wipes
- 1 x Easy to read fitting instructions.

## 6.2 Manufacturing groove and bottom pin

All the panels we manufacture are produced with a 'v' shaped groove to the top and the bottom. The purpose of this groove is to provide additional space and surface area for the silicone sealant to adhere to.

Both the Splashseal and Bottom Profile are manufactured with a small prong situated on the base of the profiles. The purpose of the prong is to support the panel at a recommended distance from the base of the profile allowing a sufficient silicone seal to be created when the panels are fitted.

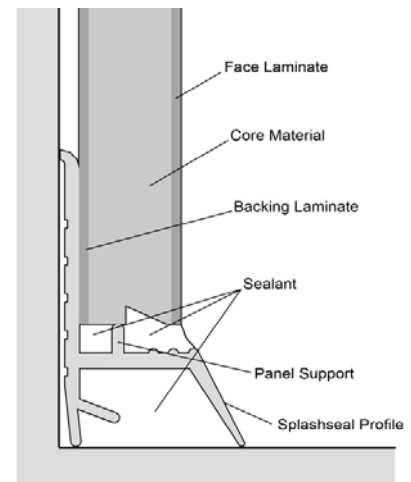

## 7.0 Tools & Fixings

Tools and fixings that you will need to install the panels include –

- **Jigsaw, circular saw or hand saw**
- **Screwdriver**
- **Mastic Gun**
- **Measuring tape & pencil**
- **Masking Tape**
- **Panel Adhesive**
- **Silicone Sealant**

## 8.0 Fitting Tips

### 8.1 Sizing & Cutting

Before cutting you should make sure that you have taken into account any allowances for profiles that are to be used which are shown below.

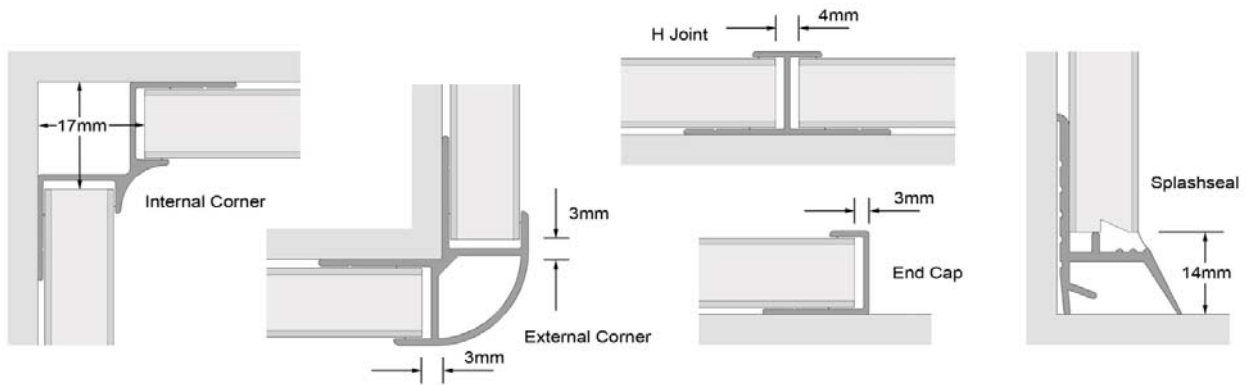

When cutting the panels to width and height using a jigsaw with an 'up-cut' blade or with a circular saw then the decorative side of the panel should be facing down.

If cutting using a hand saw then the decorative side should be facing up.

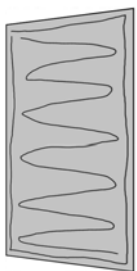
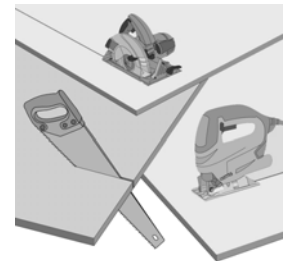

### 8.2 Adhesive application

When applying adhesive to the back of the panel to be fitted to a continuous surface we would recommend a 6mm bead applied just inside the perimeter and then zig-zagged down the middle.

### 8.3 Masking

Preparing the panels with masking tape before sealing can save a lot of time cleaning off excess sealant later on in the installation, especially at the bottom joints where a larger covered seal will be formed.

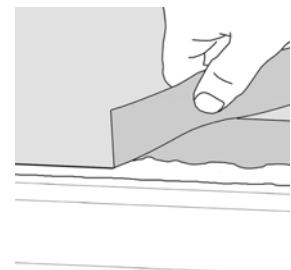

### 8.3 Adhesive & Sealant Beads

By cutting the nozzle of the panel adhesive or silicone tube at an angle you direct the flow to make application easier. The higher up the nozzle you cut the larger the diameter of the bead that will be applied. As a guide –

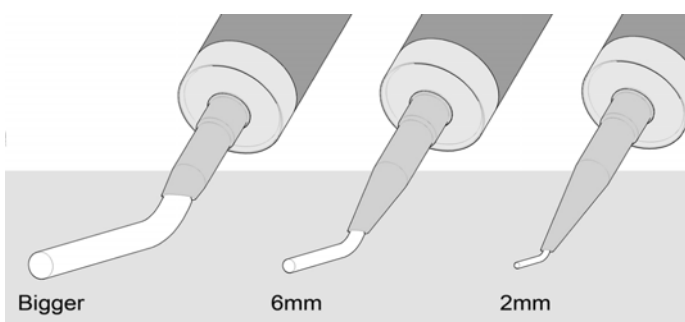

- 2mm for a sealant bead on the front lip of a tongue & grooved panel.
- 6mm for most profile joints. This will give a 2mm deep bead in the bottom of a profile channel.
- Bigger for adhesive application depending on wall surface.

## 8.4 Sealing at the bottom

If a Splashseal profile is not being used then a 3mm - 4mm gap must be left between the bottom of the panel and top of the shower tray or bath, this can be achieved by using packers when fixing panels. The gaps should then be sealed ensuring that the silicone is forced into the void.

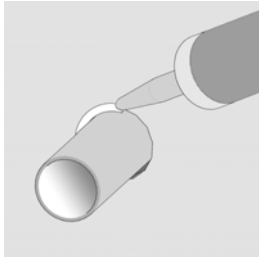
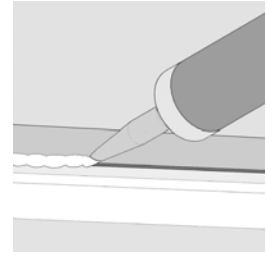

## 8.5 Sealing at apertures & Cut-outs

A clearance gap of 2-3mm all around should be allowed where pipes or fittings come through the panel even where collars are to be fitted. The gap should then be filled with sealant.

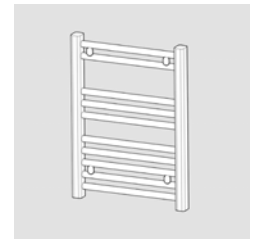

## 8.6 Fitting through Splashwall

Fittings such as shower attachments, screens, towel rails, etc. can be fixed directly through the panels using suitable fixings. Heavy items will need solid fixing points behind the panels to provide the necessary support, these should be considered when planning your installation.

## 9.0 Two Sided Shower Installation – Steps

The following steps assume that the panels and trims have been cut to the required size and that they have been dry fitted to check assembly and that if Splashseal profiles are being used they have been fitted as detailed in the Splashseal installation instructions.

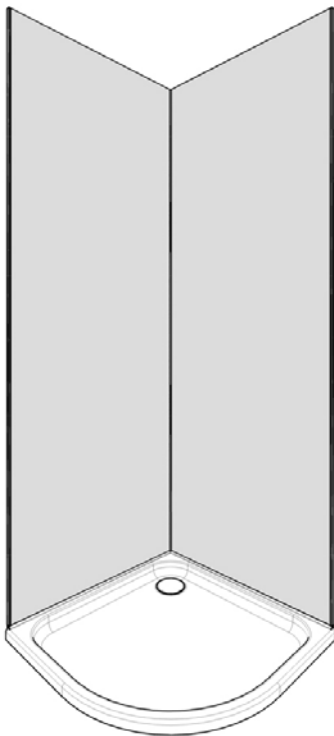

1. Fit an internal corner profile (a) into the corner using appropriate fixings, if using screws then ensure that the heads are countersunk to prevent fouling when fitting the panel.
2. Apply a bead of sealant into one side of the internal corner profile, the amount of sealant applied should cover the channel bottom to a depth of at least 2mm (6mm diameter bead).
3. Peel back the protective film from the edge of the panel that is to be fitted. Repeat this on the opposite edge if an End Cap profile is required and fit the End Cap to the edge of the panel using a 6mm diameter bead of sealant.
4. If a Splashseal profile is not being used then a 3-4mm gap should be left between the bottom of the panel and the top of the shower tray or bath, this can be achieved by using packers which will be removed before sealing.
5. Apply a generous amount of adhesive to the back of the panel. Insert the edge of the panel into the internal corner at an angle ensuring that a good seal is achieved then swing the panel into place against the wall applying pressure over the surface to ensure a good bond.
6. Repeat steps 2-5 for the second panel.
7. Seal the bottom of the panels and any apertures required as detailed in the fitting tips section or on the Splashseal installation instructions.

## 10.0 Three Sided Shower Installation – Steps

The following steps assume that the panels and trims have been cut to the required size and that they have been dry fitted to check assembly and that if Splashseal profiles are being used they have been fitted as detailed in the Splashseal installation instructions.

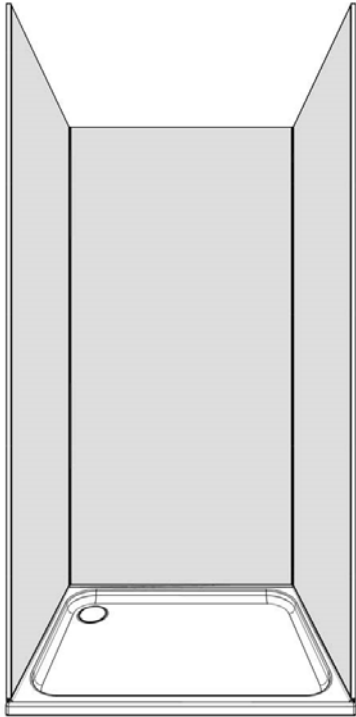

1. Fit one of the internal corner profiles (a) into the corner using appropriate fixings, if using screws then ensure that the heads are countersunk to prevent fouling when fitting the panel.
2. Apply a bead of sealant into the back wall channel of the internal corner profile, the amount of sealant applied should cover the channel bottom to a depth of at least 2mm (6mm diameter bead).
3. Peel back the protective film from the vertical edges of the back panel. Fit the other Internal Corner to the opposite edge of the back panel using a 6mm diameter bead of sealant.
4. If a Splashseal profile is not being used then a 3-4mm gap should be left between the bottom of the panel and the top of the shower tray or bath, this can be achieved by using packers which will be removed before sealing.
5. Apply a generous amount of adhesive to the back of the panel. Insert the exposed edge of the panel into the first internal corner at an angle ensuring that a good seal is achieved then swing the panel back into place against the back wall applying pressure over the surface to ensure a good bond.
6. Take one of the side panels and peel back the protective film from the edge that is to be fitted. Repeat this on the opposite edge if an End Cap profile is required and fit the End Cap to the edge of the panel using a 6mm diameter bead of sealant.
7. Apply a 6mm diameter bead of sealant into the remaining channel of the required internal corner profile.
8. Apply a generous amount of adhesive to the back of the side panel. Insert the exposed edge of the panel into the internal corner at an angle ensuring that a good seal is achieved then swing the panel back into place against the side wall applying pressure over the surface to ensure a good bond.
9. Repeat steps 7-8 for the remaining side panel.
10. Seal the bottom of the panels and any apertures required as detailed in the fitting tips section or on the Splashseal installation instructions.

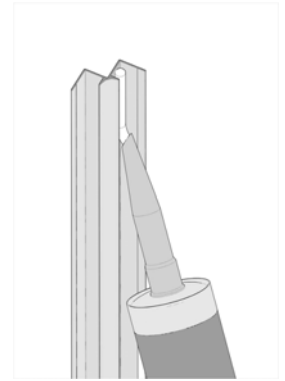



## 11.0 Full Room Installation - Steps

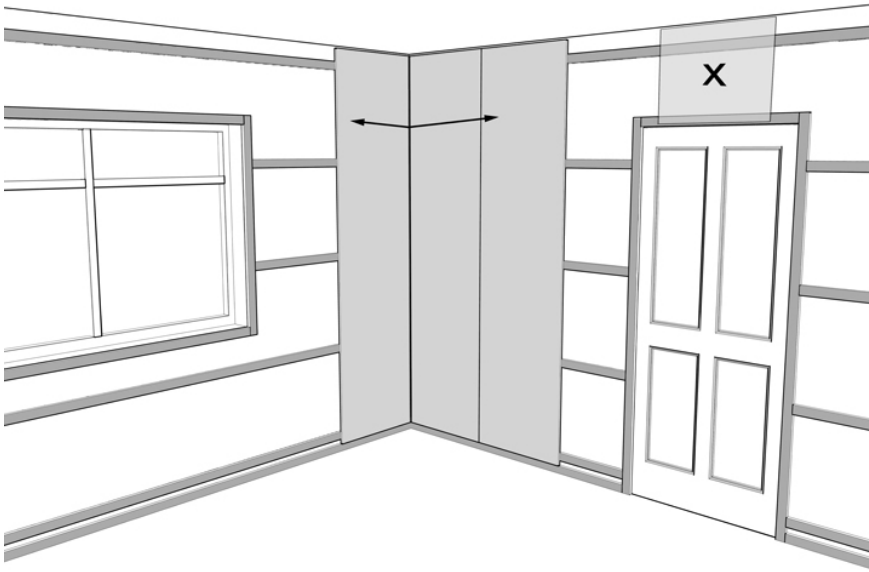

The following steps assume that the panels and trims have been cut to the required size and that they have been dry fitted to check assembly and that if Splashseal profiles are being used they have been fitted as detailed in the Splashseal installation instructions. Tongue & groove joints must be –

- Dry fitted to ensure they are sufficiently tight and flush
- Sealed with silicone sealant

When fitting panels to all the walls in a room or even a single wall wider than 1200mm, consideration should be given to the position of the joints to avoid having a narrow strip at the end of a run. Where possible, equalise the panels from a central point so that both ends are of an equal width. The last panel 'x' should always be positioned above a door or over a window as the length of the joint will be shorter and both edges require dressing.

1. Start the installation of your panels in a corner or at an end by fixing the appropriate profile in position.
2. Remove the protruding part of the tongue from the edge of the first panel.

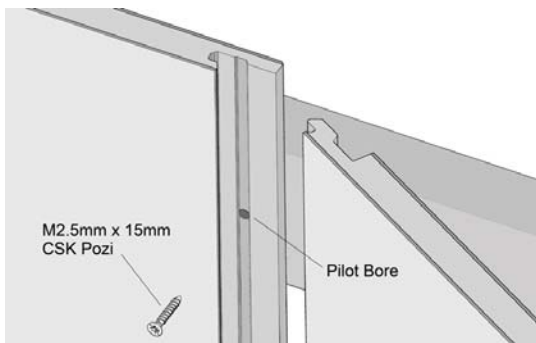
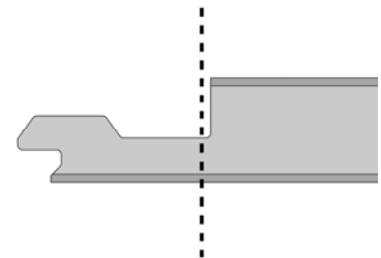

3. Locate the panel into the profile then mark the position of the required fixing points on the other end of the panel. Pilot bore the back lip of the panel with a No.3 high speed drill where the screws are to be located to fix the panel to the framing. (*failure to pilot bore may result in the panels splitting*).
4. Apply a 6mm diameter bead of panel sealant into the channel of the profile.

5. Apply a generous amount of panel adhesive to the face of the framing where the panel is to be fitted.
6. Peel back the protective film slightly then Insert the cut edge of the panel into the profile then press back onto the framing. Fix the panel in place using M2.5 x 16mm non-corrosive countersunk screws.

Ensuring that the screws are turned until they are just under the flush to prevent any obstruction to the tongue of the next panel to be fitted.

- Pilot bore the back lip of the next panel. Peel back the protective film from both panels and apply masking tape to the edges to be jointed. Apply a small bead of sealant (2mm diameter) to the front edge of the tongue.

**DO NOT put sealant into the groove as this will prevent the joint from closing.**

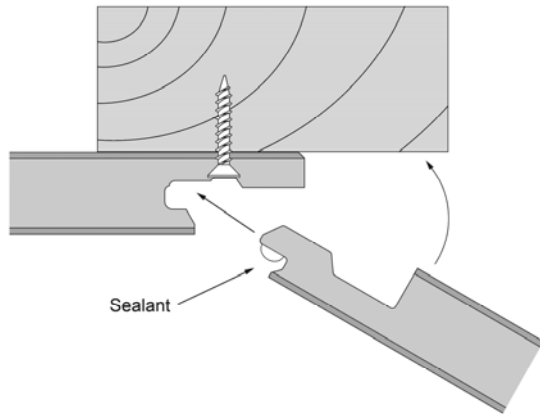

- With adhesive applied to the framing, locate the tongue of the panel into the groove of the fitted panel at an angle of about 30°. Ensure that the tongue is located along the length of the joint then applying pressure in the direction of the joint, swing the panel back towards the wall until you feel it connect. Check the joint is flush and level then press the face of the panel back onto the framing and screw in position.

- Repeat steps 7 – 8 for subsequent panels.

- The final joint which has been positioned to fall over a door way or window will need to be prepared. Before fitting panel 'a' the protruding part of the groove should be removed taking care not to damage the machined edge. The panel should then be fixed back to the framing with adhesive alone. If door facings are to be applied after panel fitting then screws which will later be concealed could be used.

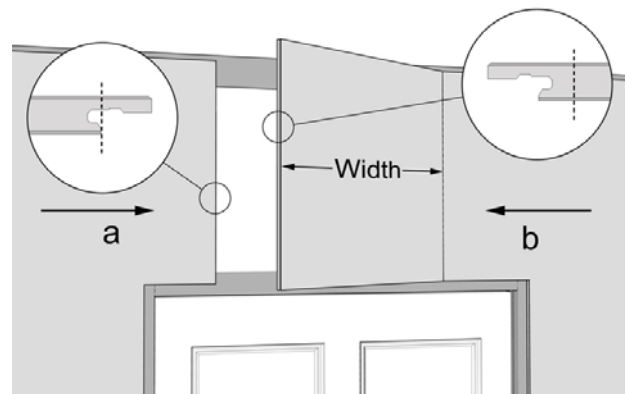

- Size and cut panel 'b' around the door frame and then fit in place as detailed in steps 7-8.

- Measure and cut the final panel to size removing the remaining groove.

- With adhesive applied to the framing, locate the tongue of the panel into the groove of panel 'b' at an angle of about 30°. Ensure that the tongue is located along the length of the joint then applying pressure in the direction of the joint, swing the panel back towards the wall until you feel it connect. Check the joint is flush and level and the butt joint at the other end is flush then press the face of the panel back onto the framing. Screw in position if possible.

## 12.0 Bottom & Skirting Details

Depending on the type of installation there can be various options for finishing the bottom of the panel but in all cases it is essential that they are sealed adequately.

If the panels are being fitted above a bath or a shower tray, a Splashseal profile is advised, as the bath or shower trays are liable to be flexible if plastic, or uneven if ceramic.

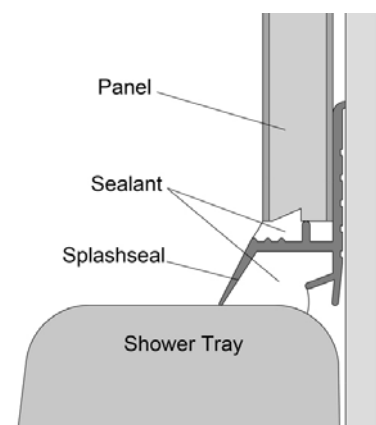

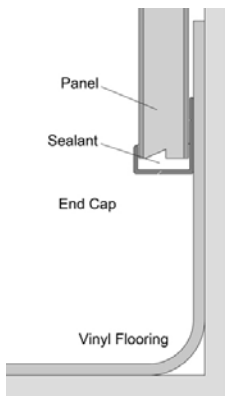

In wet areas we do not recommend that the panels are fitted right down to the floor, a gap of at least 80mm should be left.

A coved tile or PVC skirting is the preferred option with the panels sitting on a bottom profile or end cap, both of which allow the panels to sit on a neat bed of panel sealant for added protection.

Using a bottom seal will ensure that the silicone will always provide a barrier against water ingress that would have a detrimental effect on the panels at some future date.

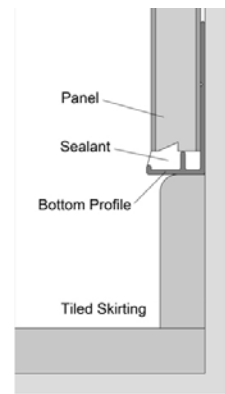

If due to the nature of the installation it is impossible to use a bottom seal then it is essential that the panels are fitted leaving a minimum 3mm - 4mm gap between the bottom of the panel and top surface to be fixed to, this can be achieved by using packers when fixing panels in place.

The gaps should then be sealed ensuring that the silicone is forced into the void.

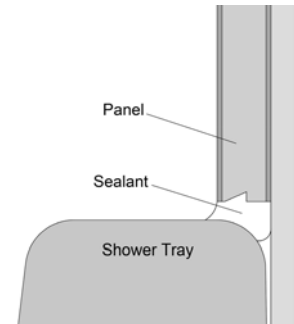

### 13.0 Window, Door & Finishing Details

There are various ways of finishing the panelling around windows and doors which will dependant on the surface the panels have been fixed to, the window or door framing detail and the look you prefer.

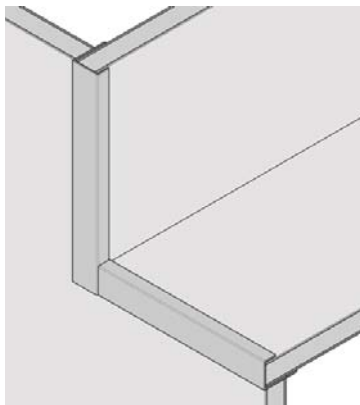

Edges can simply be silicone sealed into existing frames or capped off with profiles. Corner joints can be formed using End Caps or with External Corners, although this later method can be quite tricky and requires the profiles to mitred in a 'standing' position as illustrated.

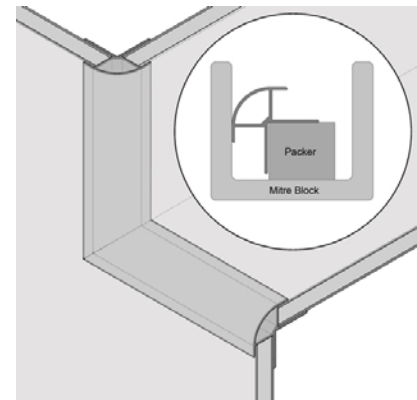

### 14.0 Cleaning

The panels can easily be kept clean with warm water and a very mild detergent. Where there are more stubborn stains, please contact the manufacturer's agent for more specific advice.

***Under no circumstance should you clean your panels with an abrasive cleaner or any other abrasive material.***

Shore Laminates Limited  
Friarton Bridge Park  
Perth  
PH2 8DD

t. 01738 634455  
f. 01738 441622  
e. [sales@shorelaminates.com](mailto:sales@shorelaminates.com)